

SVM series

Gauge selector valve



SVM GENERAL INFORMATION

Technical data

Accessories

Gauge selector valve

Gauge isolator valves are designed to protect pressure gauges from pressure shocks when the pressure reading is not required; after each reading setting the selector to the closed position serves to depressurize the pressure gauge by means of the T fitting connected to the reservoir.

Working instructions:

- Knob not pressed: pressure gauge isolated
- Knob pressed: pressure gauge reading
- Knob pressed and turned: the knob remains in position and pressure gauge measures pressure continuously.
- To isolate the pressure gauge from pressure reading, turn the button until it returns to the not pressed position.

Materials

- Body: Cast iron
- Pin: Steel
- Seals: NBR, FPM
- Cover: Anodized aluminium
- Flange: Anodized aluminium
- Knob: Polyamide
- Ringnut: Polyamide
- Nut-screw: Galvanized steel, Phosphatized steel

Operating pressure

400 bar

Operating temperature

From -25 °C to + 100 °C

Weight

SVM version 3 1.547 kg
SVM version 6 1.507 kg



Designation & Ordering code

COMPLETE GAUGE ISOLATOR VALVE

Series	Configuration example :				
SVM	SVM	3	G1	A	P01
Version					
3	3 pressure ports				
6	6 pressure ports				
Connection					
G1	G 1/4"				
G2	1/4" NPT				
G3	SAE 5 - 1/2" - 20 UNF				
Seals					
A	NBR				
V	FPM				
Execution					
P01	MP Filtri standard				
Pxx	Customized				

SVM
version 3

SVM
version 6

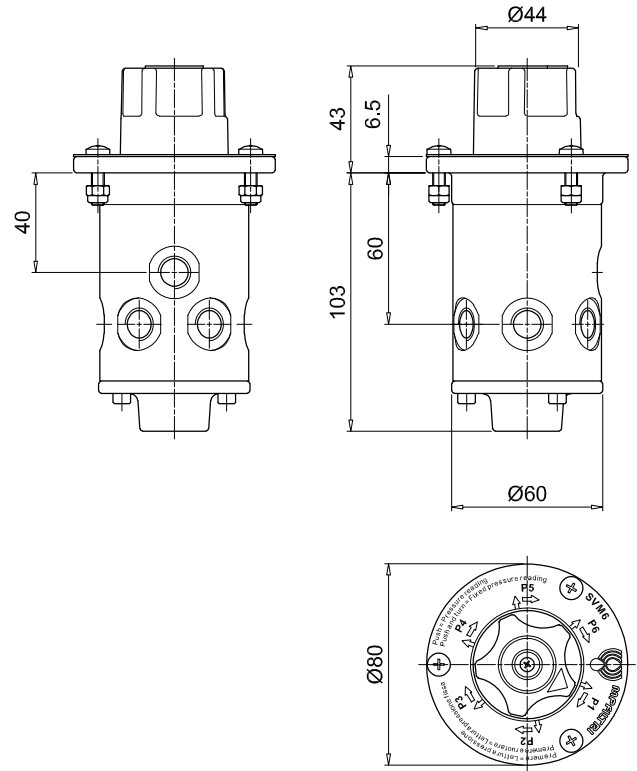
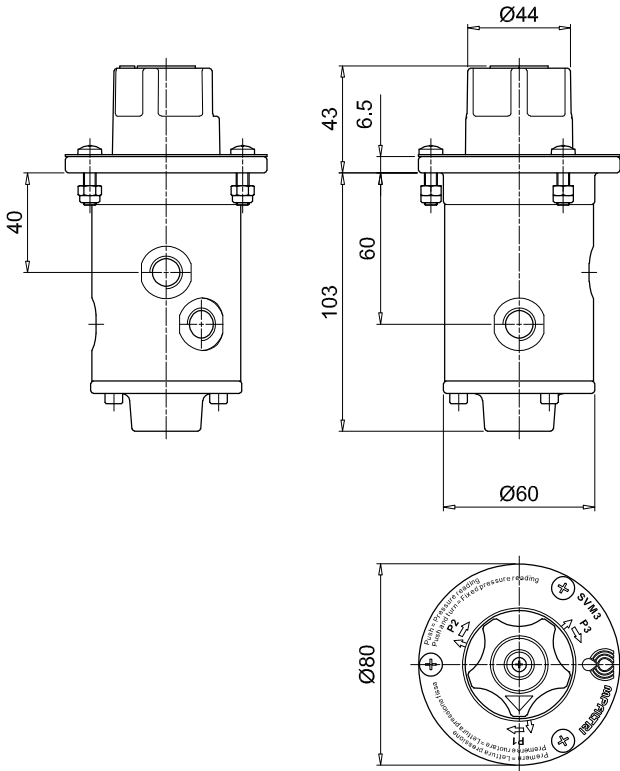

External mount

Internal mount

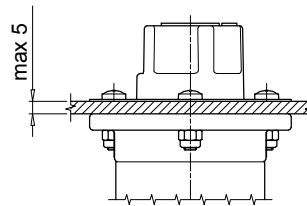
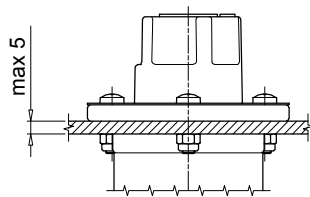

Holes on the panel

